



medemagroup





Contents

Quick guide to the Mini Crosser Nordic	4
Introduction	4
Control panel	5
Seat rotation	7
Steering column	8
Charging	9
Serial number	11
Driving the Mini Crosser E	11
Getting in and out	11
When driving in traffic.....	13
Electromagnetic compatibility	13
Brakes	14
Own notes	15



Quick guide to the Mini Crosser Nordic

Introduction

Congratulations on your new electric mobility scooter, Mini Crosser Nordic. You have now taken possession of an electric mobility scooter developed for outdoor driving by active users. It is what is called a Class C vehicle in accordance with the European classification of electric scooters.

For optimum enjoyment of this vehicle - and to avoid breakdowns and accidents - we recommend that you read the User Manual carefully. As a new user, you should pay particular attention to the section entitled "Driving the Mini Crosser Nordic."

Note:

This Quick Guide is to be regarded as a supplement to the User Manual. The information in the Quick Guide cannot, therefore, be expected to be complete.

NB: Errors and omissions excepted. Specifications subject to change.

We reserve the right to update this guide as required.

Warning!

The vehicle must not be lent to persons who are not completely familiar with it.

The vehicle is designed for one person only.

Max. user weight 140 kg.

Medema Production A/S is not responsible for any damage or injuries caused by inappropriate or unsafe use of the Mini Crosser.



Control panel

Avoid subjecting the control panel to jarring and knocks. Take care when driving and avoid hitting obstacles.

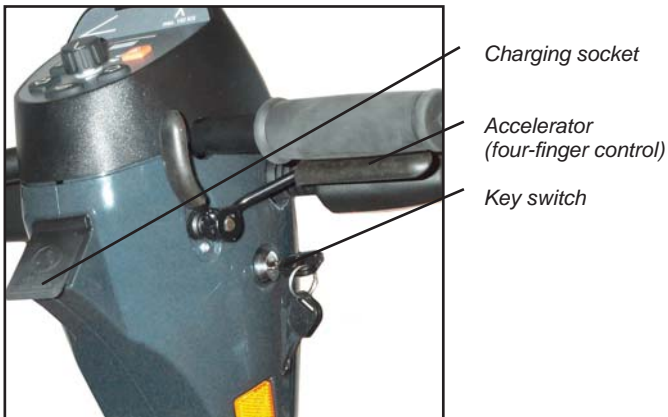
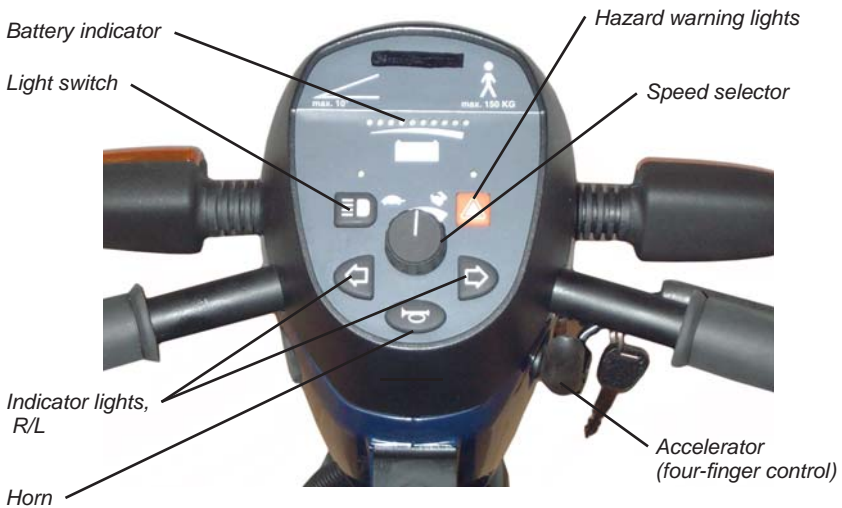

Designation	Description
Key switch	To start the vehicle: Turn the key to driving position (1) When the Mini Crosser is turned on, the control system performs a safety check of the electrical system. The check lasts half a second. If the accelerator is operated during this time, the Mini Crosser will not be able to move until you have turned the key to 0 and back to 1.
Speed selector	The tortoise in minimum position indicates the lowest speed range. 0-6 km/h The hare in maximum position indicates the highest speed range. Up to 15 km/h
Battery indicator	Lights up when the key is turned. Indicates, after half a second, the battery charge level. It gives a more precise indication after approx. 1 minute of driving. When the red, amber and green sections are lit, the batteries are fully charged. When the indicator is at the bottom of the amber section, the batteries should be charged as soon as possible. If only the red section is lit or flashing, the batteries must be charged immediately.
Handbrake	Acts on the rear wheel and should only be used as an extra / emergency brake and parking brake. It can be secured in locked position. Also available as a foot brake.
Accelerator (See picture below)	Activate the arm at the front slowly and the Mini Crosser will start to move forwards. The more the arm is pressed, the faster the Mini Crosser will move. When the arm is released, it will flip back to starting position of its own accord and the Mini Crosser will stop. Activating the rear arm will cause the Mini Crosser to reverse. The magnetic brake on the rear wheels will engage when the scooter is stationary and is equivalent to the parking brake on a car. The accelerator can also be used to control speed downhill. In this case the motor will act as a brake.
Light switch	Turns on the front and rear lights. The key switch must be in position 1 (driving position).
Hazard warning lights	Turns on all the indicator lights at once. Also works when the key is removed or turned to position 0 (stop position).
Indicator switch	Left arrow: indicator, left-hand side. Right arrow: indicator, right-hand side. Activate the same switch to turn the indicators off.
Horn	Powerful electric horn. Press the horn switch to activate.
Charging socket	Turn off the key switch during charging. Please note that it is not possible to drive the scooter while the batteries are charging. See also the section entitled "Batteries and charging".



Seat rotation

Pull the release lever back. The seat can be rotated 90° to either side. When the lever is released, it engages with the seat and holds it in place at 45° intervals.

The release lever is normally mounted on the right, but can be put on the left if so wished.

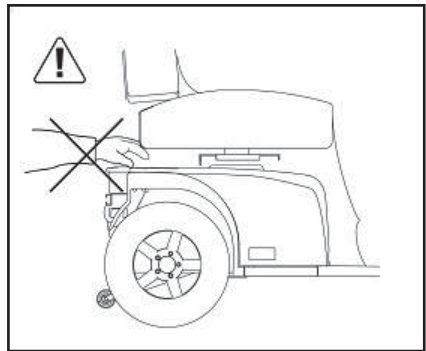

Release lever for seat rotation. Release lever for seat forward/back.

Steering column

Can be adjusted forward/back with the release lever. Pull down on the lever and pull the handlebars closer for a good driving position. Use the lever again and push the steering column forward to make it easier to get out.

The height of the steering column can be adjusted up/down. First remove the rubber plug covering the Allen screw. Adjust the height using a 6 mm Allen key.

Remember to retighten properly after adjusting.



Adjusting the angle of the handlebars.



Adjusting the height of the handlebars.

Charging

The Mini Crosser should be charged while not in use. The charger supplied from the factory switches to trickle charging (very low power consumption) automatically when the batteries are fully charged. You can therefore leave the charger connected until the Mini Crosser is next used. The charger cannot overcharge the batteries.

The charger will flash until charging is complete. Then it will show a steady light.

IMPORTANT!

The charger must not be placed on the seat during charging.

IMPORTANT!

Never use charging devices other than those supplied from the factory without first contacting the dealer.

For further information see the User Manual.

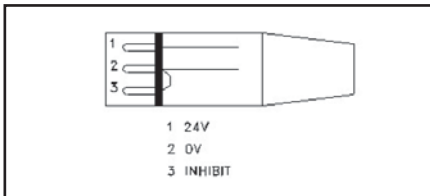

NEUTRIK NC3MX charging plug



Connect the charging plug to the 3-pin socket on the steering column. The charging socket is located under the protective cover.

If there is an electronic fault, a number of lamps in the battery indicator will light up. The following table shows what they mean.

Further information: See User manual.

Lamps	Causes	Remedy
1 lamp	The batteries need charging or the connection to a battery is poor.	Check all connections between the controller and batteries. If these are fine, try charging the batteries
2 lamps	Poor connection to the motor.	Check the connection between the motor and controller. Contact supplier.
3 lamps	Short-circuit between the motor and a battery connection.	Contact supplier - say how many lamps are lit.
4 lamps	Not in use	
5 lamps	Not in use	
6 lamps	The motor has overheated.	Stop the unit and wait 3-5 minutes before restarting. Turn the key to 0 and then to 1 to reset the fault.
7 lamps	Accelerator fault.	Make sure that the accelerator is in neutral when the Mini Crosser is turned on.
8 lamps	Controller fault.	Contact supplier.
9 lamps	Poor connection to motor brake or magnetic brake is disengaged.	Check the connections from brake to controller, or push the brake lever up. Check that the vehicle is not disengaged.
10 lamps	The controller has been supplied with a high voltage in excess of 38 V. Usually seen in the case of a poor connection.	Check all connections from the batteries to the controller.
Running lights	Charger is connected.	Remove charger.



Serial number

All vehicles have a serial number plate showing the year of production and serial number. The same serial number can also be found on the front of the User Manual.

Please quote this number when making inquiries about servicing, spare parts, etc.

Driving the Mini Crosser E

Getting in and out

It is important to learn a safe technique for getting in and out of the Mini Crosser.

In general the following method should be followed:

- Make sure that the Mini Crosser E is off (switch turned to 0) when getting in and out, otherwise the Mini Crosser could start if the accelerator was touched inadvertently.
- Make sure that the brake is on. (Lever for disengaging motor in down position.)
- Put the steering column in vertical position.
- If necessary, turn the seat through 45° or 90° and make sure that it is locked in position (clicked into place).
- If necessary, raise the armrest.

IMPORTANT!

The Mini Crosser will turn itself off automatically after it has been stationary for 10 minutes even if the key has been turned to driving position.

To restart the vehicle, the key must be turned to stop position (0) and then to driving position (1).



General safety advice:

- Make sure that the backrest is upright and the seat is as low as possible.
- Positioning belts are recommended if the user is unable to maintain a good driving posture independently.
- Adjust your driving to road conditions. Take account of light, traffic and weather. Be particularly careful when driving in the dark or in bad weather, such as rain or snow. Avoid driving on gradients with poor surfaces, such as: snow, ice, new-mown grass, wet grass and wet leaves.
- Never drive when under the influence. This applies not only to alcohol but also to drugs and medicines.
- Reduce speed immediately if you feel you are losing control.
- Always use the indicators when changing direction.
- Check that lights and indicators are working before driving off. Use your lights when driving after lighting-up time.
- As far as possible, grip the handlebars firmly with both hands.

Take care not to have anything in the basket at the front that might inadvertently operate the accelerator.

WARNING! Do not lower the handlebars so far that the accelerator can hit you on the leg when you turn the vehicle and so be operated in advertently. If the handlebars need to be very low, a twist grip accelerator is recommended. This is particularly relevant if leg supports are being used.

ALWAYS switch the scooter off when it is not in use. Turn the key to 0.

Note!

Do not drive the Mini Crosser when intoxicated. This applies to both medicine and alcohol.



When driving in traffic...

Be particularly aware of the following when driving in traffic:

- The Mini Crosser is a low vehicle and not always easy for other road users to see. Make quite sure that other road users have seen you before driving onto the highway.
- Keep an eye on traffic behind you. Keep well over to the side of the road when driving on busy roads.
- Turning right and left at crossroads. Be aware of cyclists and pedestrians. Follow the rules of the road for cyclists.
- How quickly things are happening. How long do the lights stay green? How quickly are cars approaching? etc.

Electromagnetic compatibility

If the Mini Crosser starts making involuntary movements or if the brakes are released, turn the Mini Crosser off as soon as it is safe to do so. In certain circumstances a Mini Crosser can set off shop alarms.

The Mini Crosser satisfies the requirements for the use of scooters in an environment with electromagnetic noise. There may, however, be rare situations in which electromagnetic noise can affect the Mini Crosser. Sources of such noise include radio and television stations, amateur radio transmitters and mobile phones.

If such equipment is being used close by, it is recommended that the Mini Crosser is switched off. **Mobile phones should not be used while driving.**



Brakes

There are three braking systems on the Mini Crosser E.

- Motor brake
 - Magnetic brake
 - Handbrake
- Motor brake: adjusts vehicle speed also when going downhill.
 - Magnetic brake: automatic and comes on when accelerator is released. It also acts as a parking brake when the Mini Crosser is at a standstill. In an emergency, the Mini Crosser can be stopped instantaneously by turning the key switch. Please note that this will cause very sharp braking. The rear wheels will lock!
Must not be used in the normal course of driving!
 - Electric safety brake - if the brake is somehow disengaged on a slope/hill, the Mini Crosser will brake automatically when it reaches a certain speed. There is an electric safety feature in the control system, which works even if the battery is disconnected. This is also the reason why the Mini Crosser cannot be towed at more than 5 km/h. See the section about towing.
 - Handbrake: intended as an emergency brake and parking brake. It must be operated with caution when driving in slippery conditions and downhill.



Own notes





medemagroup